

VIPER CRUSHER VPCH-21

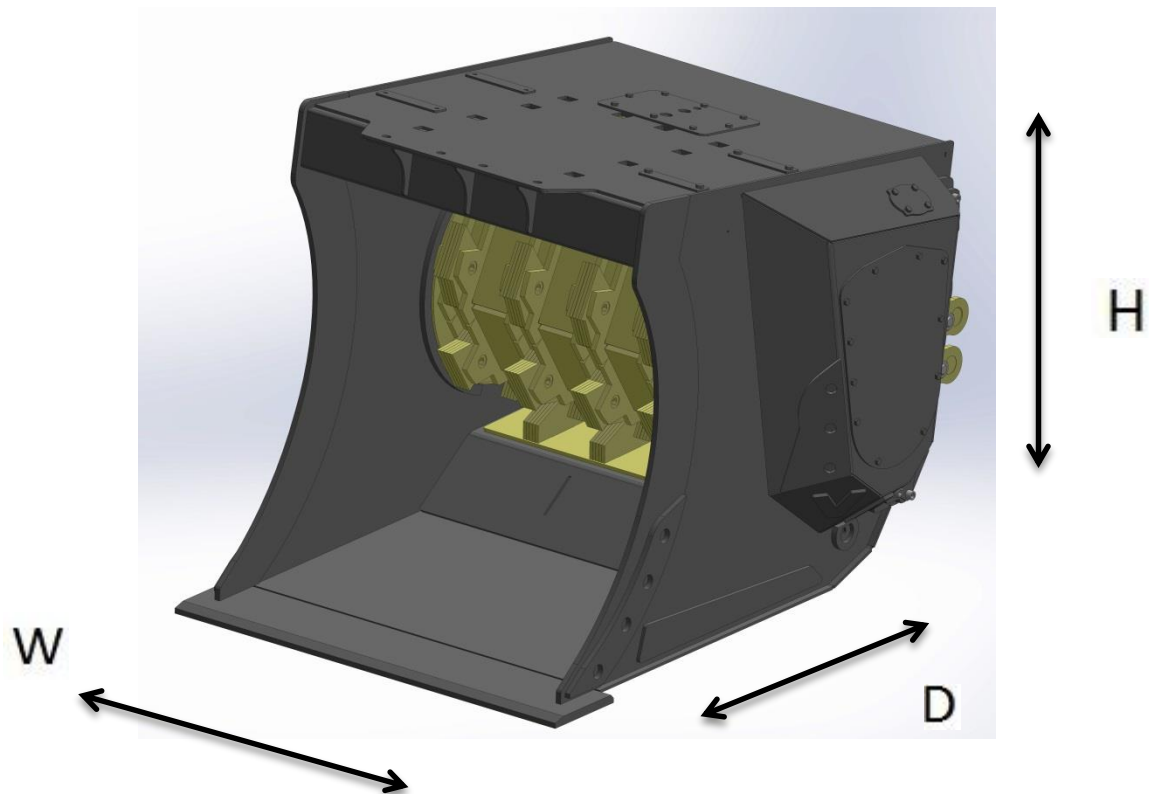

INFORMATION	www.vipermetal.fi
Width, bucket [mm] (W)	1500
Width, rotor [mm]	1150
Depth [mm] (D)	1800
Height [mm] (H)	1350
Weight [kg]	2300
Volume ISO [m ³]	0,95
Volume SAE [m ³]	1,3
Recommended excavator (tons)	22-30
Grain size [mm]	40-150
Recommended Oil flow	250-440
Recommended Oil pressure	330